

1 2 3 4

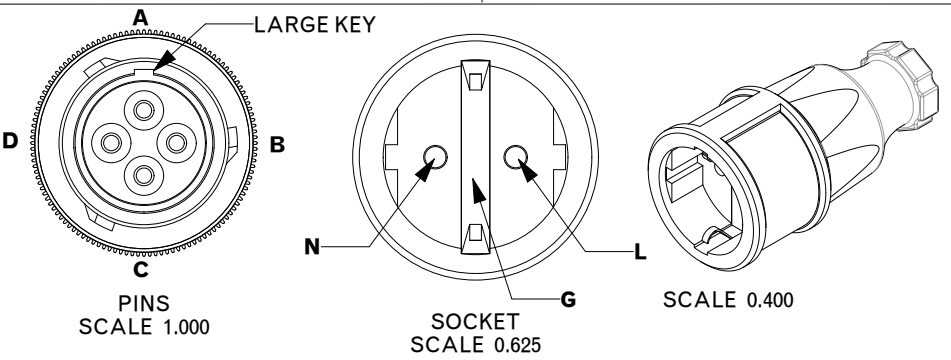

REVISIONS			
REV	DESCRIPTION	DATE	APPROVED
A	INITIAL RELEASE PER ECO 19-25424	07/23/19	K.DUBROWN

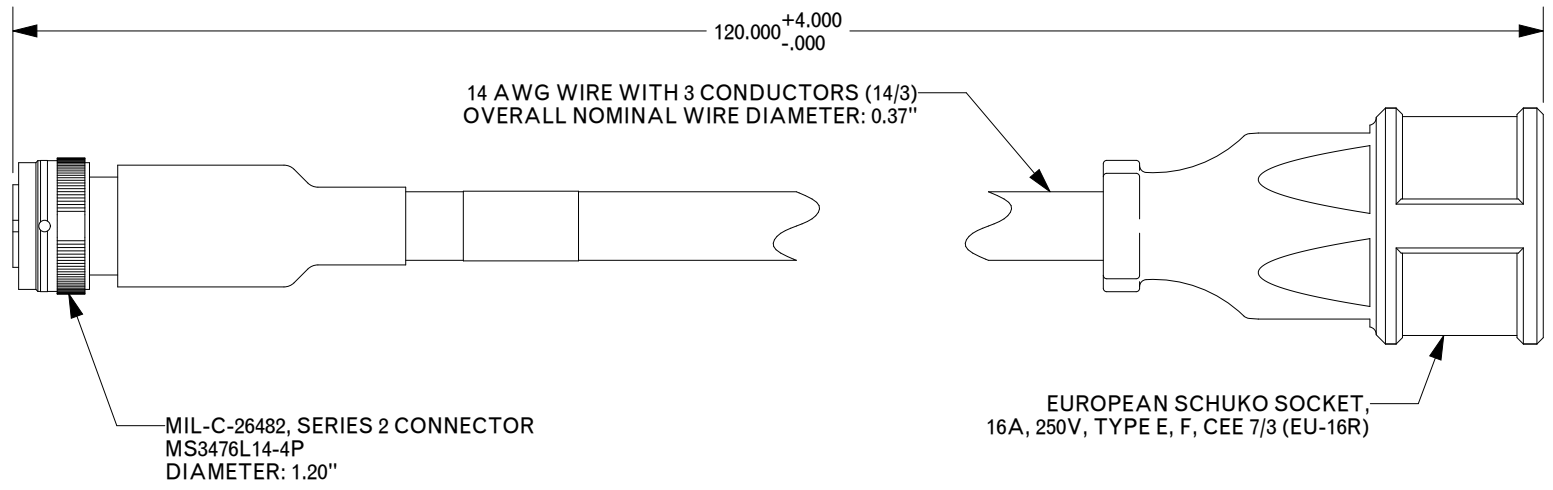

PIN IN #	WIRE COLOR	DESCRIPTION	PIN OUT #
A	BROWN	LINE	L
B	BLUE	NEUTRAL	N
C	NO CONNECTION	NO CONNECTION	
D	GREEN WITH YELLOW STRIPE	GROUND	G

C

NOTES:

1. REFERENCE SYNQOR SPECIFICATION: 705-1000297
2. PRODUCT WEIGHT: 2.6 Lbs

TOLERANCES:

Unless otherwise specified:
 All dimensions in inches

- .X +/- .025
- .XX +/- .010
- .XXX +/- .005
- Angles +/- 1°

THIRD ANGLE PROJECTION

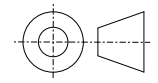

THIS DRAWING IS THE PROPERTY OF SYNQOR INC.
 It is not to be reproduced or copied, in whole
 or in part, or used for furnishing information
 to others, or for any purpose detrimental to the
 interests of SynQor. The information shown herein
 may be protected by patents owned or controlled by SynQor.



155 Swanson Road
 Boxborough, MA 01719

UPS AC OUTPUT, 10' LENGTH,
 SCHUKO 16A 250V SOCKET

SOURCE: PRO/E INT_CONFIG_SCHUKO_70161-HD

SIZE	DATE	DWG. NO.	REV
A	JUL-23-19	SYN-9146	A
SCALE: 0.600	DRAWN: KJD	CHECK:	SHEET 1 of 1

1 2 3 4